

# BoosterBox Construction for Free-mo Layouts

By Larry Sebelley

Chilliwack Model Railway Club – Free-mo Division

## Introduction

When creating a large Free-mo layout, or any other large modular layout, for the purposes of power distribution it is desirable to divide the layout into separate power districts. Each such power district must be connected to the Command Station to receive its instructions; but must receive power to its tracks from a separate booster. To minimise the set-up time by creating easily accessible connections, I have designed what I call the BoosterBox. It is housed in a tool box and contains a Digitrax DB150, Digitrax PS515 power supply, cooling fan, and the necessary connections. The Digitrax DCS100 Command Station is housed in a similar tool box, with the matching connections.

This article lists the parts as specified and the method of construction. If you use the same parts, you can follow the instructions precisely. If you substitute similar but compatible parts, you will need to modify the construction accordingly.

The entire project takes about four hours to complete. You can, of course, do it a step at a time, at your leisure. Let's get started.

## Phase 1: Gather the Parts, Supplies, and Tools

The first step in this project is to gather the parts and supplies. Figure 2 is a detailed list of the parts I use and the most recent cost for each. I have not priced the Digitrax or NCE parts, as you will have your own preferred supplier. The electronic parts can be purchased (or ordered) from your local electronics store. If you live in the Lower Mainland of BC, consider using SMI Electronics in Langley. The toolbox itself is available only from Home Hardware, as it is their house brand, Benchmark. It is very “square” so lends itself nicely to this project.



Figure 1 – Benchmark Tool Box

You will need some common hobby and construction tools: utility knife, X-Acto knife, ruler, tape measure, soldering gun, soldering iron, flux and solder, screwdrivers, power drill (cordless), and drill bits. A hole saw will be helpful to cut the circular hole for the fan. A step-drill bit is also of great value

in drilling the appropriate holes. I recommend using a cordless drill, as it is easier to control while drilling slowly through the plastic tool box.

## BoosterBox Parts List

Make	Qty	Part No.	Description	Cost
Benchmark	1	1112-147	16.5 inch Tool Box	\$ 22.40
Belkin	1	F9H600fc04	Surge Master Power Bar	\$ 16.80
Cinch	1	S-302-AB	Flush Plate Socket	\$ 2.50
Cinch	3	P-302-CCT	Plug - 2 pin	\$ 21.50
Cinch	3	S-302-CCT	Socket - pin inline	\$ 21.50
Newark	2	108-0904-001	Banana Jack - Green	\$ 2.00
Newark	2	108-0304-001	Banana Plug - Green	\$ 4.10
	1	46-101-1	SPST Round On-Off Rocker Switch	\$ 4.40
	1	59-264-0	12 VDC 2 inch Cooling Fan	\$ 7.80
	1	59-316-0	2 inch Finger Guard	\$ 1.50
	1	68-125-1	12 VDC Adapter	\$ 12.30
	1	31-045-1	110 VAC Chassis Jack	\$ 2.00
	1	31-035-0	110 VAC 3-conductor Power Cord	\$ 6.60
	4	12-256-0	6P6C Plugs	\$ 1.10
	6		6-conductor Loconet Cable	\$ 6.70
Digitrax	1	DB150	Empire Builder	
Digitrax	1	PS515	Power Supply	
NCE	1	UTP	Universal Throttle Panel	
TOTAL PARTS COST				\$ 133.20

Figure 2 – BoosterBox Parts List

You will also need a supply of stranded 12 gauge wire (white, black, and green) and a supply of stranded 20 gauge wire (white, black, and red). You will also need 1/8" stove bolts, flat washers, and lock washers.

### ***Phase 2: Preparation of the Input End of the Box***

Looking at the front of the tool box, the input end is on the left. Our goal is to drill and cut two holes in the input end; one for the power cord and one for the cooling fan. Refer to the drawing in Figure 3 for the measurements.

## BoosterBox Input End

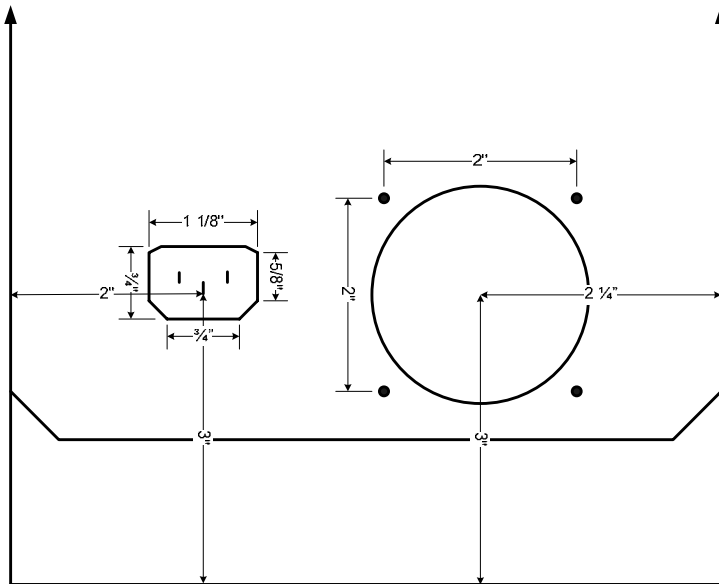

Figure 3 – Input End Measurements

Measure from the bottom of the tool box up 3 inches, and from the rear of the tool box right 2 inches. This spot will mark the Ground connection on the 110 VAC Chassis Jack. With your utility knife and X-Acto knife, carefully carve a bottom-angled, rectangular hole in which to mount the Chassis Jack, referring to the drawing in Figure 3. The hole should surround the previously marked spot. Be careful not to press too hard so as to not carve too rapidly. The hole should be 1 1/8 inch wide by 7/8 inch tall. Angle the two bottom corners at 45 degrees to match the shape of the Chassis Jack. There is not much room for error, and this is the most finicky step in the project. Once you have the Chassis Jack set in the carved hole, mark the two holes for the mounting screws. Drill these with a 1/8 inch drill bit. Trim any plastic flash around the holes with your knife.

The next step is to drill the holes for the Cooling Fan. Measure from the bottom of the tool box up 3 inches, and from the front of the tool box left 2 1/4 inches. This spot will mark the centre of the Cooling Fan. At the centre point, drill a 2 1/4 inch diameter hole. This is most easily accomplished with a hole saw, using the cordless drill on low speed. Low speed is needed to minimise the amount of plastic melted in the process. If you don't have access to a hole saw, you could try a sabre saw on low speed, but the hole would be less regular. Once the hole is drilled, use the 2-inch Finger Guard to mark the location of the 4 mounting holes. Drill these with a 1/8 inch drill bit. Trim any plastic flash around the holes with your knife. Your prepared input end should look like Figure 4. Do not install the Chassis Jack or the Cooling Fan/Finger Guard yet. Be patient.



Figure 4 – Input End Holes

### **Phase 3: Preparation of the Output End of the Box**

Looking at the front of the tool box, the output end is on the right. Our goal is to drill and cut five holes in the output end; one for the NCE Universal Throttle Panel (UTP), one for the auto-reversing Rocker Switch, two for the green Banana Jacks, and one for the Flush Plate Socket (Cinch Jones). Refer to the drawing in Figure 5 for the measurements.

## BoosterBox Output End

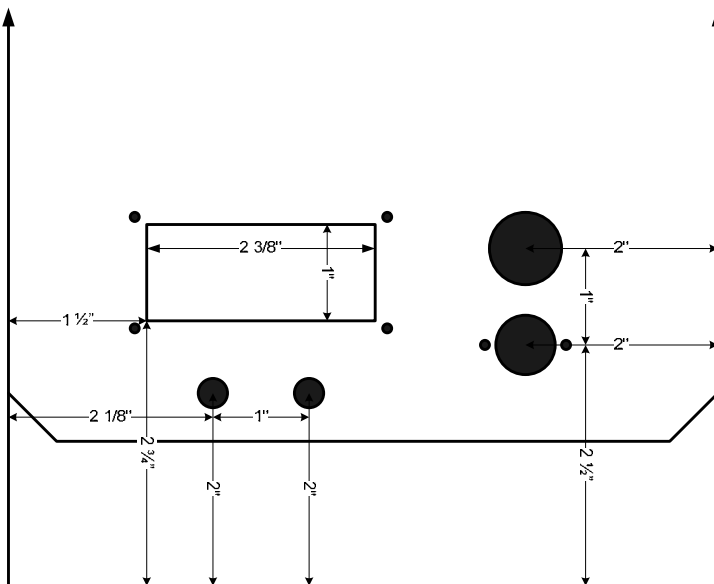

Figure 5 – Output End Measurements

Measure from the bottom of the tool box up  $2\frac{3}{4}$  inches, and from the front of the tool box right  $1\frac{1}{2}$  inches. This spot will mark the bottom-left corner of the NCE UTP hole. From that marked point, use your utility knife to cut a rectangular hole to the right  $2\frac{3}{8}$  inches and up 1 inch. Temporarily insert the

NCE UTP, attached to its cover plate, and mark the location of the 4 mounting holes. You will probably wish to mount the UTP upside-down so that the tabs on the Loconet cables will be facing upwards, as they do in Digitrax UP5 panels. Drill these holes with a 1/8 inch drill bit. Trim any plastic flash around the holes with your knife.

**[SIDEBAR]** You may wonder why I use the NCE UTP instead of a Digitrax UP5. The UP5 has certain circuitry on board that causes the Railsync signal to be stopped from exiting through the two front Loconet jacks. The result is that a booster connected to Loconet through the front of the UP5 will not communicate with the command station. The NCE UTP does not have such circuitry, and merely shares all 6 Loconet connections among all 4 of its jacks. I believe that Tony's Train Exchange offers a UTP of their own design, and I do believe it works as does the NCE UTP does.

Measure from the bottom of the tool box up 2 inches, and from the front of the tool box right 2 1/8 inches. This spot marks one of the holes for the ground cable socket. From that spot measure right 1 inch to mark the spot for the second ground cable socket. Drill these with a 5/16 inch drill bit. Trim any plastic flash around the holes with your knife.

Measure from the bottom of the tool box up 3 1/2 inches, and from the rear of the tool box left 2 inches. This spot marks the hole for the On-Off Rocker Switch. Drill this with a 3/4 inch drill bit. Trim any plastic flash around the hole with your knife.

Finally, measure from the bottom of the tool box up 2 1/2 inches, and from the rear of the tool box 2 inches. This spot marks the hole for the Flush Plate Socket (Cinch Jones). Drill this with a 5/8 inch drill bit. The step drill bit in the cordless drill works very well for this step. Once the hole is drilled, use the Cinch Jones socket oriented horizontally, to mark the location of the 2 mounting holes. Drill these with a 1/8 inch drill bit. Trim any plastic flash around the hole with your knife.

All the required holes are now prepared and your input end should look like Figure 6. However, do not install any of the components yet. Again, be patient.



Figure 6 – Output End Holes

#### ***Phase 4: Installation of the Major Components***

This phase is when we install the interior components and connections. Begin by cutting a 14 1/2 inch by 6 inch piece of 3/8 (or 1/2) inch plywood for the base. The goal is for it to sit into the bottom of the tool

box, remaining quite firmly placed so as to avoid movement. For aesthetic reasons, you may wish to paint the plywood black to match the tool box.

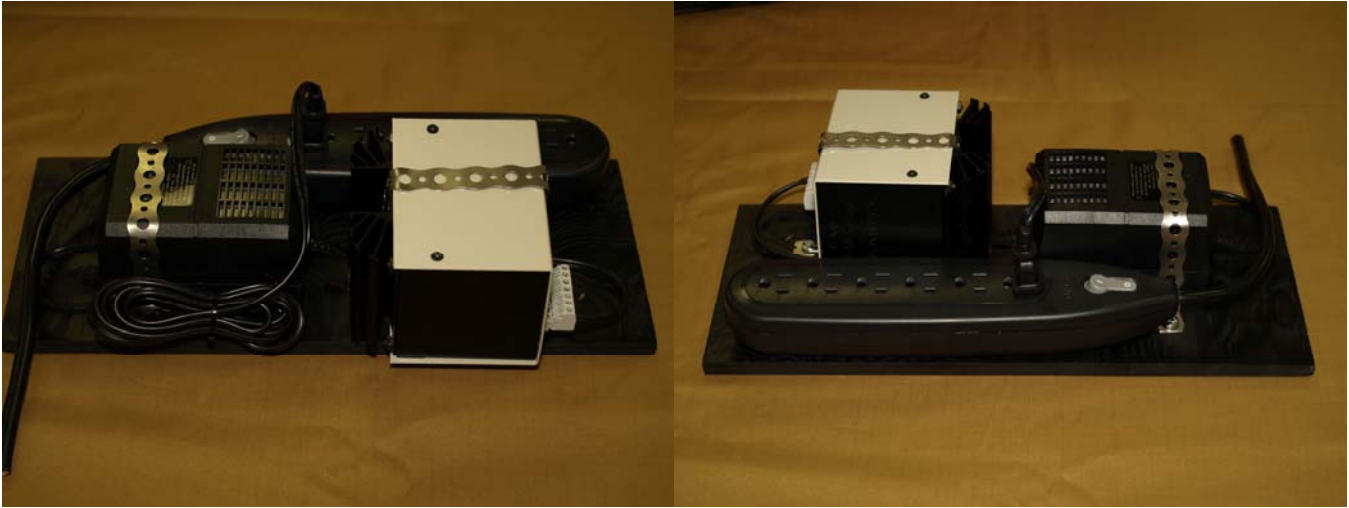

Figure 7 – Major Components

Cut the cord off the power bar, leaving 6 inches of cord attached to the power bar body. Strip the outside insulation back 2 inches, strip each of the 3 wires back ¼ inch, and then crimp on 3 solderless flat-blade connectors. Determine the location for the power bar on the plywood by placing it into to the tool box. You will want the power bar to be snug to the back of the tool box, and about 1 inch from the right end of the tool box. Mount the power bar to the plywood using two appropriate screws, securely enough to avoid movement.

Next to be mounted in the tool box is the DB150 booster. Locate it 3 ½ inches from the right end of the tool box, and snug up to the side of the power bar. There is little room to spare at the front of the tool box. I have used plumber’s pipe-hanging metal strapping over the DB150, forming screw mounts at the front and rear of the DB150. Use two large-head, short-thread screws to attach the strapping to the plywood base.

The final major component to install is the PS515 power supply. Locate it behind the DB150 about 1 inch away from the cooling fins on the back of the DB150. Attach the PS515 to the plywood base with the plumber’s strapping and two screws. The output cord should be routed underneath the DB150, cut to length and connected to the *Power In* terminals on the DB150. The input cord can be rolled, tied, and tucked to the side of the PS515.

Figure 7 shows the major components attached to the plywood base, from the front and rear.

Set the plywood base with the major components installed into the bottom of the tool box.

### ***Phase 5: Installation of Minor Components and Connecting the Wires***

The next phase is to install all of the other components and to connect them together. Begin with the output end of the BoosterBox.

Start by installing the Cinch Jones In-Line Socket into the bottom right hole that has been prepared. Insert the socket from the inside of the tool box, with the wide blade at the bottom, and secure it with two 1/8 inch stove bolts, flat washers, and lock washers. Connect a piece of black stranded 12 gauge wire from the *Rail B* terminal on the DB150 to the lower, wide blade of the Flush Plate Socket. Connect a piece of white stranded 12 gauge wire from the *Rail A* terminal on the DB150 to the upper, narrow blade of the In-Line Socket. You can either solder the wires to the In-Line Socket or use solderless

terminal connectors. If soldering, the power of a 140/100 watt soldering gun seems to help solder the 12 gauge wire.

Second, install the two green Banana Jacks into the two holes below the rectangular cut-out. Insert the jacks from the outside of the tool box and secure them with their own nuts. Connect a piece of green stranded 12 gauge wire from the *Ground* terminal on the DB150 to the two Banana Jacks. You can either solder the wire to the Banana Jacks or use solderless terminal connectors.

Third, install the Rocker Switch into the hole above the In-Line Socket. Insert the switch from the outside of the tool box and secure it by snapping it into place. Connect a piece of red stranded 20 gauge wire from the *Config B* terminal on the DB150 to one of the switch's connectors. Connect another piece of red stranded 20 gauge wire from the *Ground* terminal on the DB150 to the other switch's connector. You can either solder the wire to the switch connectors, or use solderless terminal connectors.

Fourth, cut and strip a 2 inch piece of white stranded 20 gauge wire. Insert this wire into the *Ground* terminal on the DB150 along with the green stranded 12 gauge ground wire and the red stranded 20 gauge auto-reverser wire. You will find it a bit of a challenge to get them all in the terminal securely and tidily. The other end of this 2 inch piece of white stranded 20 gauge wire goes into the *Config A* terminal on the DB150. This jumper wire sets the DB150 into booster-only mode.

Finally, install the NCE UTP board onto its face plate, and then insert the plate from the outside of the tool box, and secure it with four 1/8 inch stove bolts, flat washers, and lock washers. If you mount the UTP upside-down, the sockets will be in the same orientation as with Digitrax UP5 sockets. Crimp two 6P6C connectors to the ends of a 4 inch piece of Loconet cable, ensuring that Pin 1 matches with Pin 1. Plug one end into the *Loconet B* socket on the DB150 and the other end into one of the rear sockets on the UTP board. You could install an LED on the UTP board as instructed by NCE, however I felt the extra challenge would not be worth a power-on light situated below the layout.



Figure 8 – Output End Internal Connections

The output end of the BoosterBox is now complete. It should look like Figure 9.



Figure 9 – Completed Output End Connections

Next, proceed to installing the input end minor components and connections. Firstly, insert the 110 volt AC chassis jack from the outside into its prepared hole. Secure it with two 1/8 inch flat-head or stove bolts, flat washers, and lock washers. Plug the three power bar cord connectors onto their respective jack connectors, looking at the rear of the jack, from left to right: black, green, and white. You should apply heat shrink tubing to cover these bare connections, as they will have 110V AC power going through them.

The final component to be installed is the cooling fan. The cooling fan is powered by the 12 volt DC adapter plugged into the internal power bar. Cut off the moulded connector on the adapter cord, and strip the wire. Temporarily attach these wires to the wires powering the fan. The fan will run only with the feeder wires attached in one orientation. Make note of which adapter wire attaches to which fan wire to make the fan run, and also which way the fan moves the air through itself. Disconnect the adapter from the fan. Feed four long 1/8 stove bolts through the finger guard, through the tool box side and through the cooling fan frame. Ensure that the fan will blow the air out of the BoosterBox. Use four flat washers and lock washers to firmly affix the fan in place. Cut the adapter wires to length and solder them to the fan wires, according to your experiment above. Shrink wrap the solder connections to avoid short circuits.

The input end of the BoosterBox is now complete. It should look like Figure 10.



Figure 10 – Completed Input End Connections

## Phase 6: Preparation of the External Connections

The final phase is to construct the various cables to connect the BoosterBox into the Digitrax system. You will need a track bus cable plus two adapter cables, a Loconet cable, and a ground cable.



Figure 11 – Track Bus and Adapter Cables

Firstly, construct a track bus cable to connect the BoosterBox to the power district.

- Cut a 6-foot length of white stranded 12 gauge wire and a 6-foot length of black stranded 12 gauge wire. Strip each end ¼ inch.
- Solder one end of the **white** wire to the **wide** blade of a male Cinch Jones plug.
- Solder one end of the **black** wire to the **narrow** blade of the same male Cinch Jones plug.
- Slide on a cover housing to match this plug.
- Slide on another cover housing facing in the opposite direction.
- Solder the other end of the **white** wire to the **wide** blade of another male Cinch Jones plug.
- Solder the other end of the **black** wire to the **narrow** blade of that same male Cinch Jones plug.
- Push the attachment pin through each Cinch Jones connector, and tighten the clamping screws.
- You may wish to trim off the excess clamping screws after tightening them.

Secondly, to allow for a phase differential between power districts, construct an adapter cable to reverse polarity.

- Cut a 6-inch length of white stranded 12 gauge wire and a 6-inch length of black stranded 12 gauge wire. Strip each end ¼ inch.
- Solder one end of the **white** wire to the **narrow** blade of a male Cinch Jones plug.
- Solder one end of the **black** wire to the **wide** blade of the same male Cinch Jones plug.
- Slide on a cover housing to match this plug.
- Slide on another cover housing facing in the opposite direction.
- Solder the other end of the **white** wire to the **wide** blade of female Cinch Jones socket.
- Solder the other end of the **black** wire to the **narrow** blade of that same female Cinch Jones socket.
- Push the attachment pin through each Cinch Jones connector, and tighten the clamping screws.
- You may wish to trim off the excess clamping screws after tightening them.

Thirdly, to allow for various connection locations construct a female-to-female adapter cable.

- Cut a 6-inch length of white stranded 12 gauge wire and a 6-inch length of black stranded 12 gauge wire. Strip each end ¼ inch.
- Solder one end of the **white** wire to the **wide** blade of a female Cinch Jones socket.
- Solder one end of the **black** wire to the **narrow** blade of the same female Cinch Jones socket.
- Slide on a cover housing to match this socket
- Slide on another cover housing facing the opposite direction.
- Solder the other end of the **white** wire to the **wide** blade of another female Cinch Jones socket.
- Solder the other end of the **black** wire to the **narrow** blade of that same female Cinch Jones socket.
- Push the attachment pin through each Cinch Jones connector, and tighten the clamping screws.
- You may wish to trim off the excess clamping screws after tightening them.

Check the above three cables carefully to ensure they are constructed as specified.



Figure 12 – Loconet and Ground Cables

The Loconet cable is used to connect BoosterBox to BoosterBox or BoosterBox to Command Station, to provide an independent Loconet network, separate from the network containing the UP5s, stationary decoders, etc. The Loconet cable can be constructed any length you wish, but I recommend at least 25 feet spanning from booster to booster between the power districts. The Loconet cable is constructed using the standard cable construction method; crimping a 6P6C connector to each end of the cable. Ensure that the connectors are oriented in accordance with Digitrax specifications, i.e. pin 1 to pin 1 and pin 6 to pin 6, etc.

The Ground cable is constructed of green stranded 12 gauge wire.

- Cut a length to match the Loconet cable you have just constructed. Strip each end ¼ inch.
- Solder a Banana Jack to one end of the wire.
- Slide on a cover housing to match this jack.
- Slide on another cover housing facing the opposite direction.
- Solder another Banana Jack to the other end of the wire.
- Screw the cover housings onto their metal jacks.

## ***Phase 7: Testing***

Your BoosterBox construction project is now complete. You should test it by plugging it into an operational layout:

- Plug the power cord into the chassis jack and a source of 110V power
- Plug the track bus cable into the Cinch Jones In-Line Socket and the power district
- Plug the Loconet cable into either jack on the BoosterBox and then to the next booster/command station
- Plug the ground cable into either jack on the BoosterBox and then to the next booster/command station
- Power up the command station, power up the BoosterBox, and if all is well, the BoosterBox power district will come to life.

If there is a phase difference in the newly-created power district, insert the polarity reversing bus adapter cable (male-to-female) between the BoosterBox and the power district. If the booster is to perform an auto-reversing function, flip the rocker switch to its “on” position.



Figure 13 – Output Connections

If you care to visit our club’s website at [www.members.shaw.ca/cmrc/welcome.htm](http://www.members.shaw.ca/cmrc/welcome.htm) you will find a link to the PDF version of this article.

In the unlikely event that your new BoosterBox does not work, you will need to retrace your construction steps to find and correct the problem.

**HAPPY RAILROADING!**